

REVISIONS

| REV. | DESCRIPTION | DATE | APPRVD. |
|------|-------------|------|---------|
| | | | |

Notes:

1. System Controller can be used to connect a 2 or more unit multisystem application. When System Controller is in use, pump control and tub alarm features are disabled. Refer to SC-201-6M manual for detailed instructions in setting up system controller.
2. When using System Controller, use only a single remote controller.
3. Size the piping to allow for the maximum flow rates of the units.
4. Noritz recommends the use of Isolation Kit (IK-WV-4) with installation. These kits include an integrated shut-off and service valve with unions and a pressure relief valve.
5. Use condensate pump when drain is located far away from water heater and size for desired lift distance. For the condensate drain line, use 1/2" PVC pipe. Slope horizontal pipe downwards 1/4" per foot towards drain or condensate pump. Do not submerge or block end of drain pipe.
6. Check valve required if it is not included with the pump.
7. Expansion tank required if a backflow preventer is installed.
8. Size the pump to provide enough flow through the water heater and Brazed Plate Heat Exchanger. Refer to the manufacturer for flow requirements and performance data.

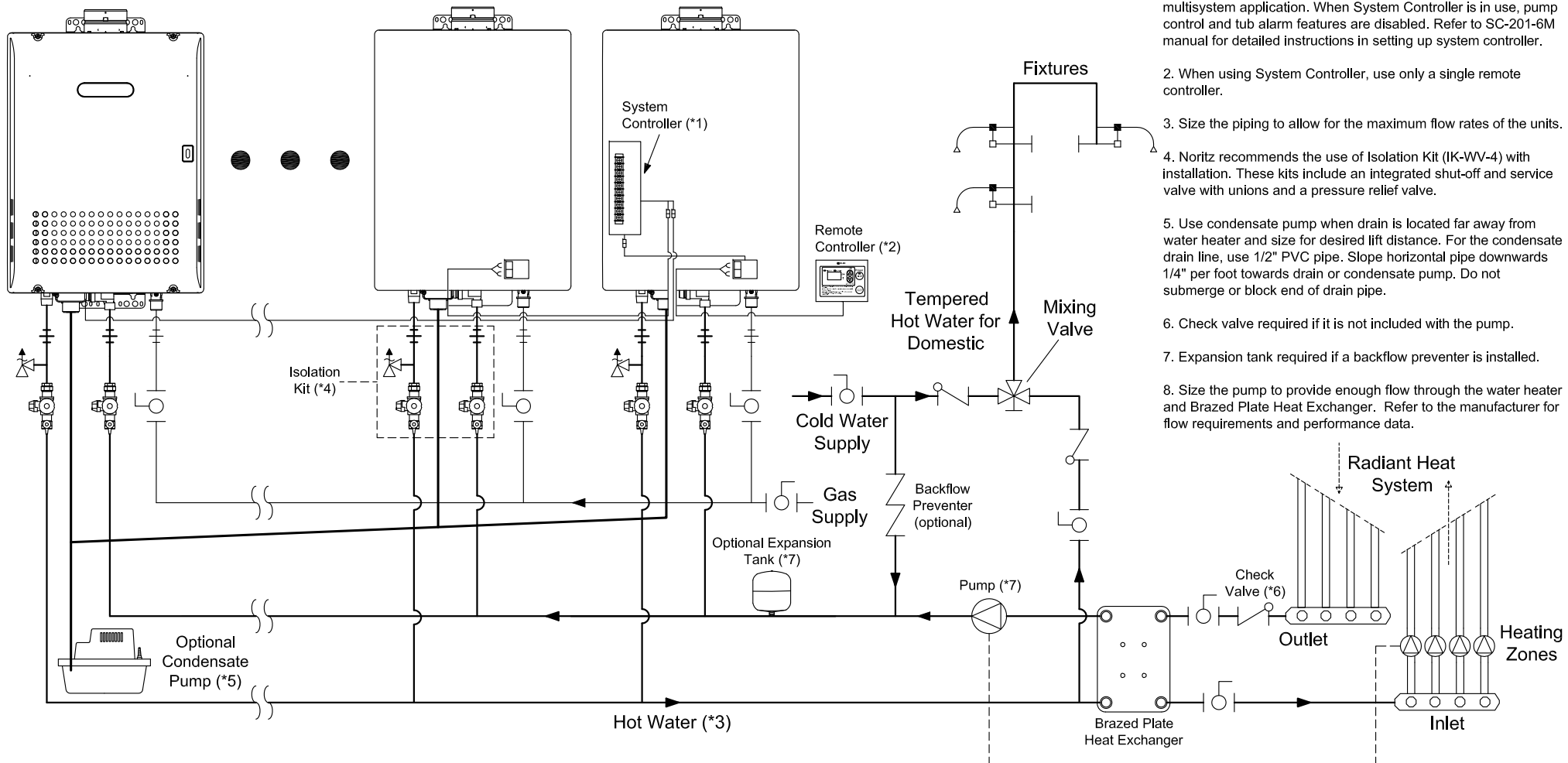

NORITZ
 11160 Grace Avenue
 Fountain Valley, California 92708
 866-7NORITZ (866-766-7489)
 www.noritz.com

MODEL:
 N-0841MC

APPLICATION:
 2-6 Unit Multi-System
 Domestic Hot Water
 Radiant Heating

DRAWING NUMBER:
 (7a2-6)N841MC

DRAWING DATE:
 September 22, 2008

Noritz Accessories

- RC-7649M (Remote Controller)
- RC-CORD10 (10' Remote Controller Cord, optional in 26')
- VC-4C (Outdoor Vent Cap, place on top of unit)
- SC-201-6M (System Controller, for 2 or more unit Multi-System)

Note: This diagram is for reference only. Installation must comply with State and Local Code, all gas and water pipe must be sized correctly to specific length, according to accepted engineering methods or the UPC Code for Noritz Water Heaters to operate correctly.

- Shut-off Ball Valve
- Check Valve
- Union
- Pressure Relief Valve (Watts 174A, Zurn P3000BR, Cash Acme F-82)
- Aquastat (Honeywell Model #L6006A or L6006C)
- Pump
- Mixing valve
- Thermal Expansion Tank