

REVISIONS

REV.	DESCRIPTION	DATE	APPRVD.

Notes:

- Noritz recommends the use of Isolation Kit (IK-WV-5) with installation. These kits include an integrated shut-off and service valve with unions and a pressure relief valve.
- Wire aquastat to pump according to "Circulation Pump to Aquastat Wire Diagram (PAWD.pdf)." Set the aquastat to 10°F below the set output temperature.
- Size the pump to provide a maximum of 2 GPM through the system at 10 ft of head plus piping losses. Adjust the flow using a globe valve and verify the flow rate with the maintenance monitors.
- System Controller can be used to connect a 2 or more unit multisystem application. When System Controller is in use, pump control and tub alarm features are disabled. Refer to SC-201-6M manual for detailed instructions in setting up system controller.
- When using a System Controller, use only a single remote controller.
- Size the piping to allow for the maximum flow rates of the units.
- Size the pump to provide a maximum of 3 GPM with a head pressure equal to the loss through the water heater and Air Handler. Check valve required if it is not included with the pump.
- Expansion tank required if a backflow preventer is installed.

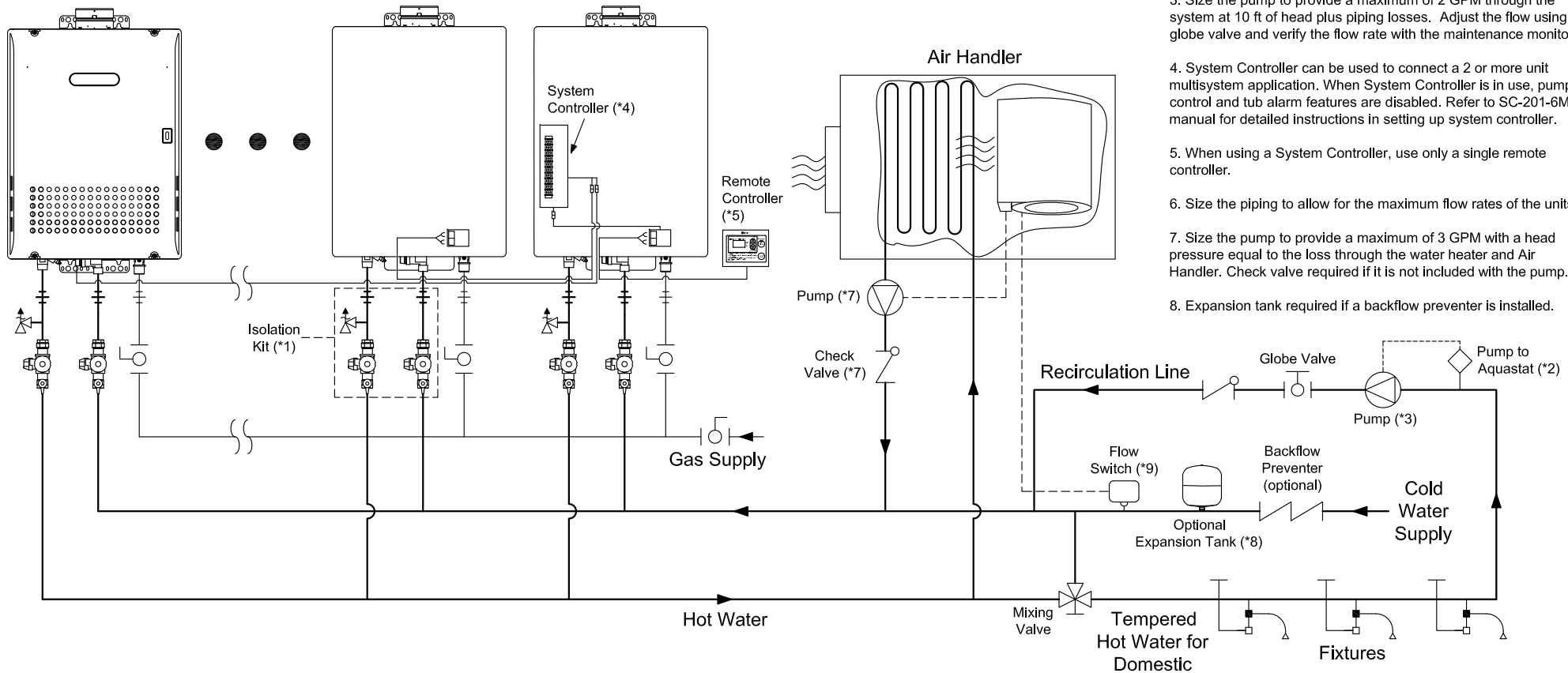

11160 Grace Avenue  
Fountain Valley, California 92708  
866-7NORITZ (866-766-7489)  
www.noritz.com

MODEL:

N-0931M

APPLICATION:

Hydronic Heating  
2-6 Unit Multi-System  
Domestic Hot Water  
Recirculation  
Primary Loop

DRAWING NUMBER:

(6b2-6)N931M

DRAWING DATE:

September 22, 2008

**Noritz Accessories**



RC-7649M (Remote Controller)



RC-CORD10 (10' Remote Controller Cord, optional in 26')



VC-4-1 (Outdoor Vent Cap, place on top of unit)



SC-201-6M (System Controller, for 2 or more unit Multi-System)

Note: This diagram is for reference only. Installation must comply with State and Local Code, all gas and water pipe must be sized correctly to specific length, according to accepted engineering methods or the UPC Code for Noritz Water Heaters to operate correctly.



Shut-off Ball Valve



Check Valve



Union



Pressure Relief Valve (Watts 174A, Zurn P3000BR, Cash Acme F-82)



Aquastat (Honeywell Model #L6006A or L6006C)



Pump



Mixing Valve



Thermal Expansion Tank