

REVISIONS

REV.	DESCRIPTION	DATE	APPRVD.

Notes:

- To achieve the highest recovery, size the storage tank circulation pump for maximum capacity (N-0841MC/N-0842MC: 8.0 gpm (each) @ 40 ft. of head (160°F setting or less) plus piping losses through the system). Verify the supply pressure to the units is at least 30 PSI.
- Thermostat of storage tank should be set 10°F below the output set temperature of the water heater.
- System Controller can be used to connect a 2 or more unit multisystem application. Refer to SC-201-6M manual for detailed instructions in setting up system controller.
- When using a system controller, use only a single remote controller.
- Size the piping to allow for the maximum flow rates of the units (1 1/4"-2").
- Noritz recommends the use of Isolation Kit (IK-WV-7) with installation. Connections are available in Threaded or Sweat. These kits include an integrated shut-off and service valve with unions and a pressure relief valve.
- Use condensate pump when drain is located far away from water heater. Size for condensate flow at 2 GPH per unit and desired lift distance. For the condensate drain line, use 1/2" PVC pipe. Slope horizontal pipe downwards 1/4" per foot towards drain or condensate pump. Do not submerge or block end of drain pipe.

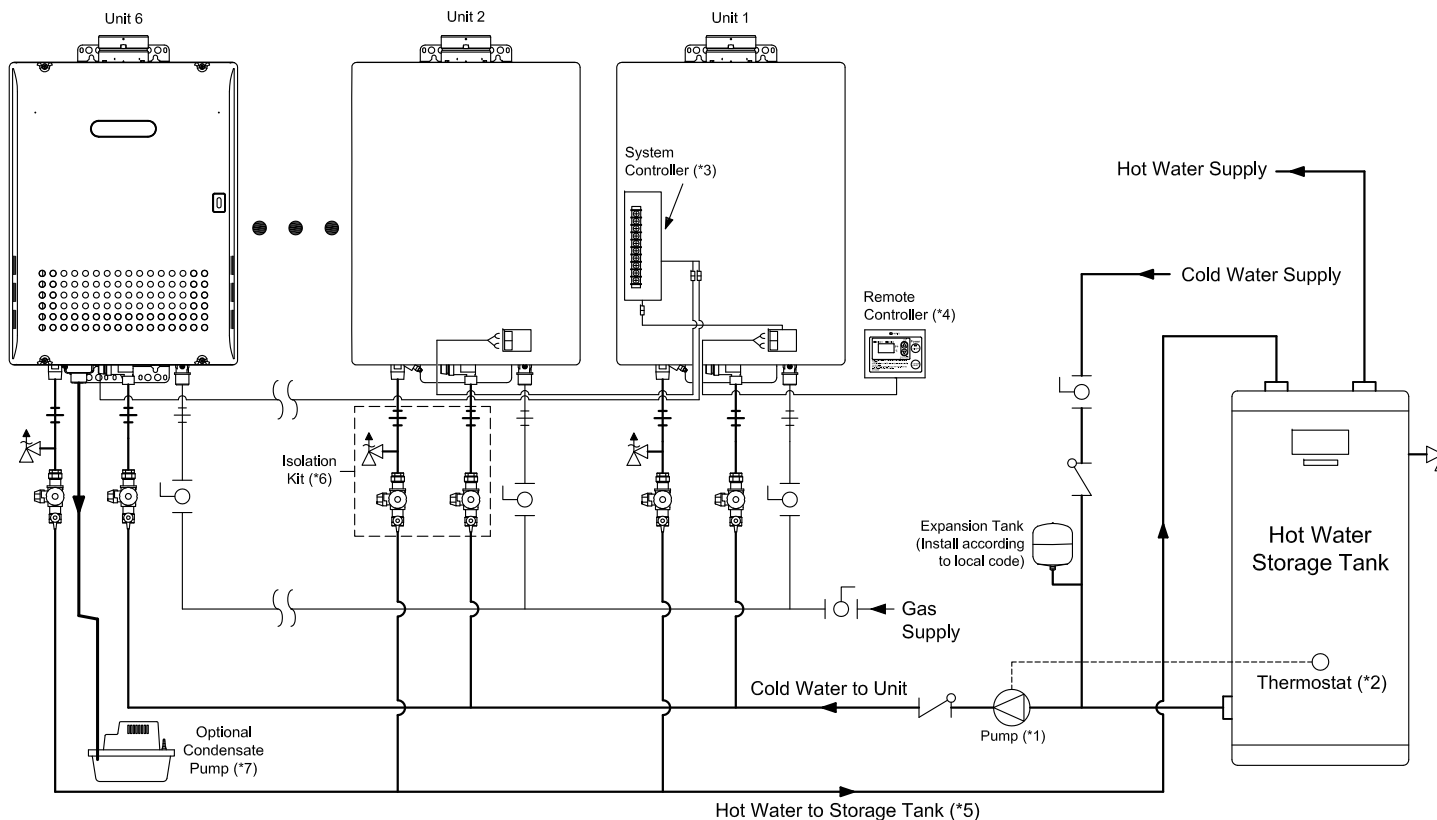

11160 Grace Avenue
Fountain Valley, California 92708
866-7NORITZ (866-766-7489)
www.noritz.com

MODEL:
N-0841MC/N-0842MC

APPLICATION:
Domestic Hot Water
2-6 Unit Multi-System
Storage Tank

DRAWING NUMBER:
(3a2-6)N841_842MC

DRAWING DATE:
August 5, 2009

Noritz Accessories

- RC-7649M (Remote Controller)
- RC-CORD10 (10' Remote Controller Cord, optional in 26')
- VC-4C (Outdoor Vent Cap, place on top of unit)
- SC-201-6M (System Controller, for 2 or more unit Multi-System)

Note: This diagram is for reference only. Installation must comply with State and Local Code, all gas and water pipe must be sized correctly to specific length, according to accepted engineering methods or the UPC Code for Noritz Water Heaters to operate correctly.

- Shut-off Ball Valve
- Check Valve
- Union
- Pressure Relief Valve (Watts 174A, Zurn P3000BR, Cash Acme F-82)
- Aquastat (Honeywell Model #L6006A or L6006C)
- Pump
- Mixing Valve
- Thermal Expansion Tank