

### NCC1991-DV

### NCC1991-OD

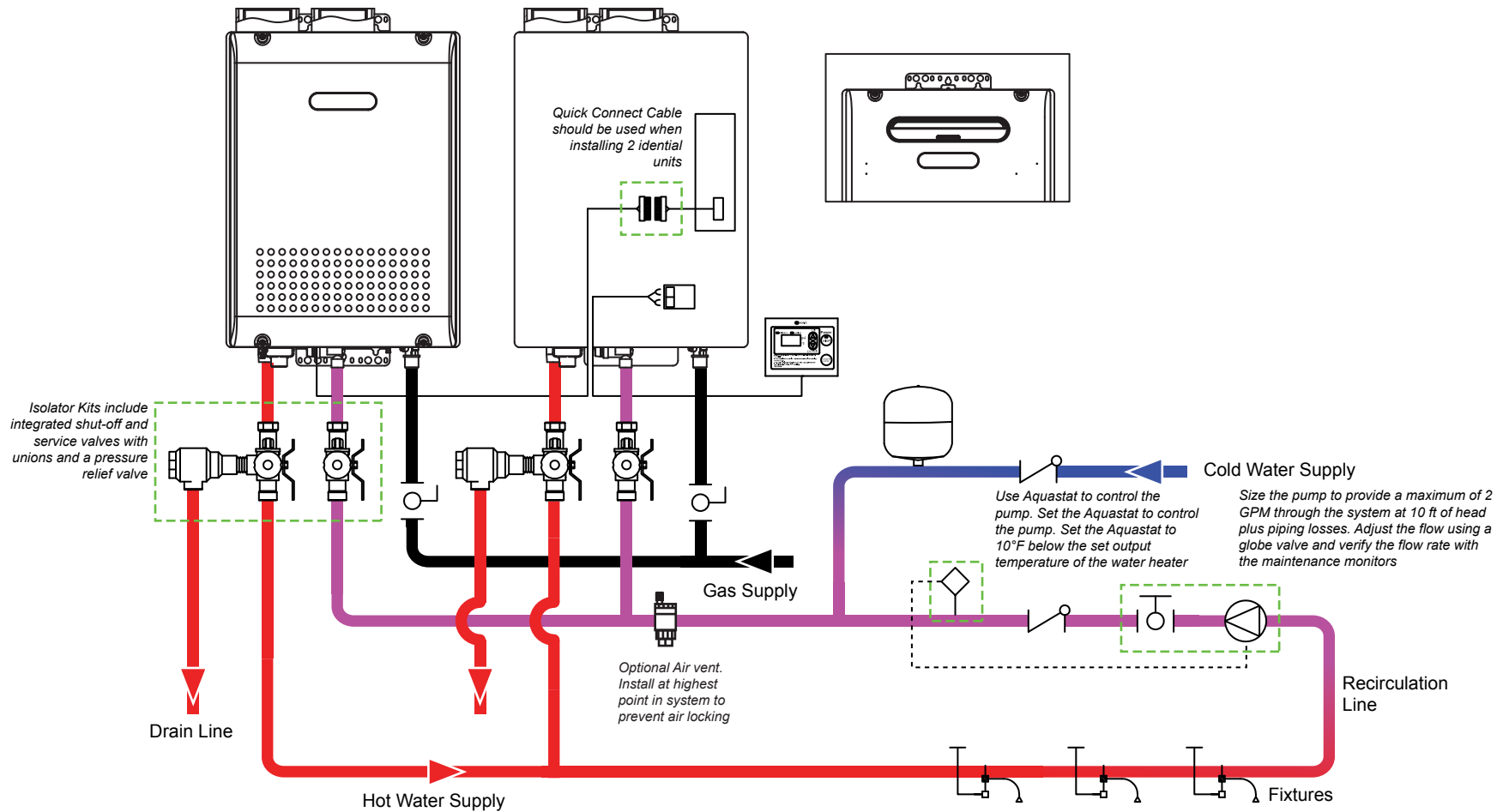

11160 Grace Avenue  
Fountain Valley, California 92708  
866-7NORITZ (866-766-7489)  
www.noritz.com

<b>MODEL</b>	NCC1991 SERIES
<b>APPLICATION</b>	COMMERCIAL RECIRCULATION- QUICK CONNECT
<b>DRAWING NUMBER</b>	(2)NCC1991-Recirculation-QC.pdf
<b>DRAWING DATE</b>	5/22/2014

EQUIPMENT LIST		
ITEM	PART #	QTY
CHECK VALVE	FIELD SUPPLIED	2
EXPANSION TANK	FIELD SUPPLIED	1
RECIRCULATION PUMP	FIELD SUPPLIED	1
AQUASTAT	FIELD SUPPLIED	1
GLOBE VALVE	FIELD SUPPLIED	1
NORITZ HEATER	NCC1991	2
REMOTE CONTROLLER	RC-9018M	1
REMOTE CONTROLLER CORD	RC-CORD10	1
ISOLATOR KIT	IK-WV-200	2
QUICK CONNECT CABLE	QC-2	1
AIR VENT	FIELD SUPPLIED	1

Note: This diagram is for reference only. Installation must comply with State and Local Code, all gas and water pipe must be sized correctly to specific length, according to accepted engineering methods or the UPC Code for Noritz Water Heaters to operate correctly.

	Shut-off Ball Valve		Aquastat (Honeywell Model #L6006A or L6006C)
	Check Valve		Pump
	Union		Mixing Valve
	Pressure Relief Valve (Watts 174A, Zurn P3000BR, Cash Acme F-82)		Thermal Expansion Tank