

System Controller SC-201-6M

Installation Manual

Potential dangers from accidents during installation and use are divided into the following two categories. Closely observe these warnings, they are critical to your safety.



WARNING

Denotes content that may result in fire, serious bodily injury and even death when ignored.



NOTICE

Denotes content that may result in bodily injury and physical damage when ignored.

Requests to Installers



WARNING

In order to use this product safely, read this installation manual carefully and follow the installation instructions.

- Failures and damage caused by erroneous work or work not as instructed in this manual are not covered by the warranty.
- Refer to installation manual attached to the appliance as well.
- Check that installation was done in accordance with this Installation Manual upon completion.
- After completion of installation, be sure to hand this Installation Manual to the customer.

1. Included Accessories

The following accessories are included with this product. Check for missing items before installing.

Part	Shape	Q'ty	Part	Shape	Q'ty
Installation Manual (this document)		1	Tapping Screw ø4 x 8		3
System Controller Mounting Plate		1	*1 Vinyl Tie		3
Cord Bushing		1			

*1 Use the vinyl ties for loose electrical wiring inside the unit.

SHA8754



SHA8754 C

Multi-System Wiring

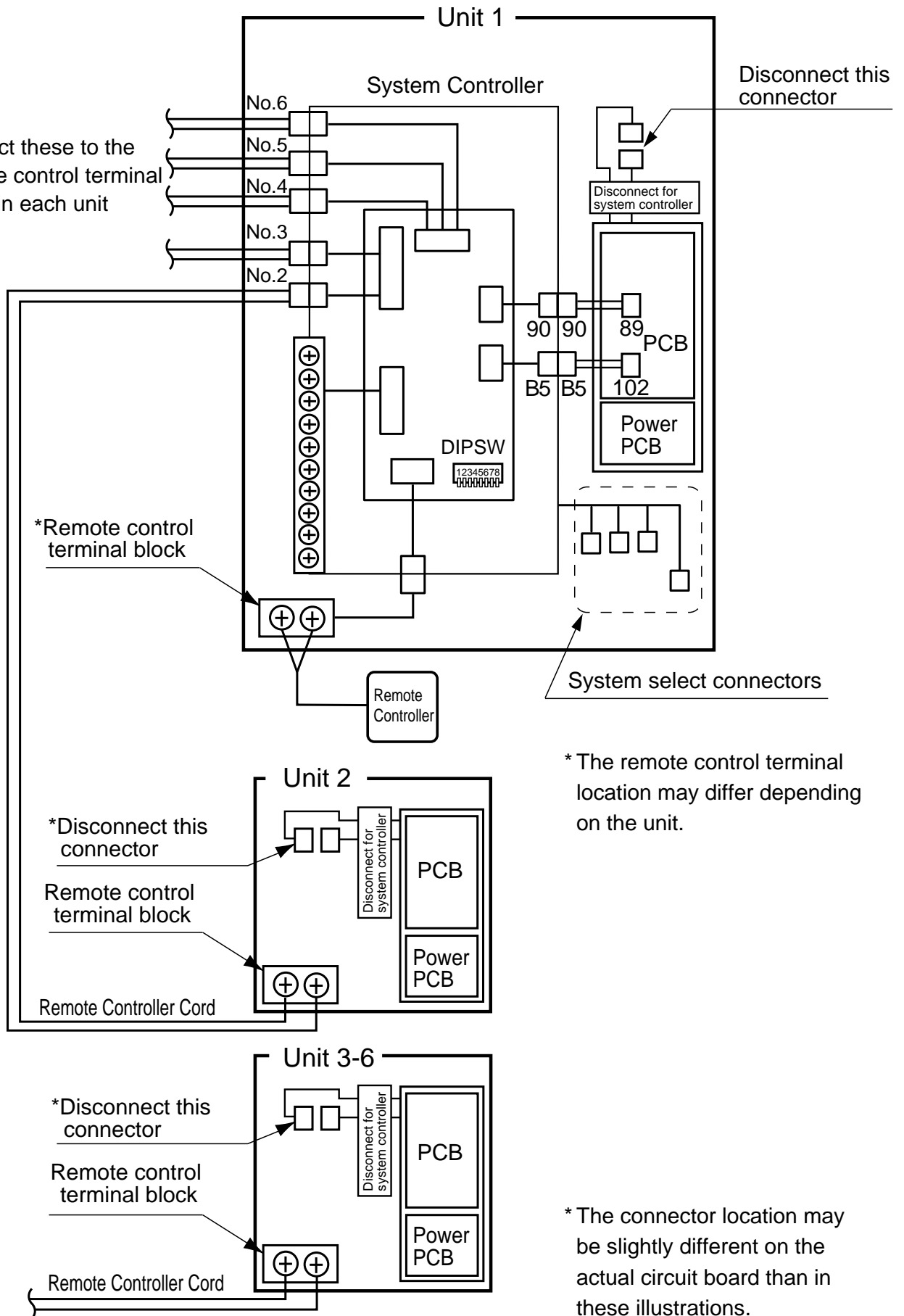

System Select Connectors

If this system will be installed with a recirculation system, a storage tank, or with a filtration system, plug the selector in to the connector that corresponds to that type of system.

* If none of these circulating systems are used, do not connect the selector.

(1) If the units will be installed in a recirculation system:

Connect the selector to the connector labeled "Recirculation System" (1).

(2) If the units will be installed with a storage tank:

Connect the selector to the connector labeled "Storage System" (2).

(3) If the units will be installed with a water filtration system:

Connect the selector to the connector labeled "Filtration System" (3).

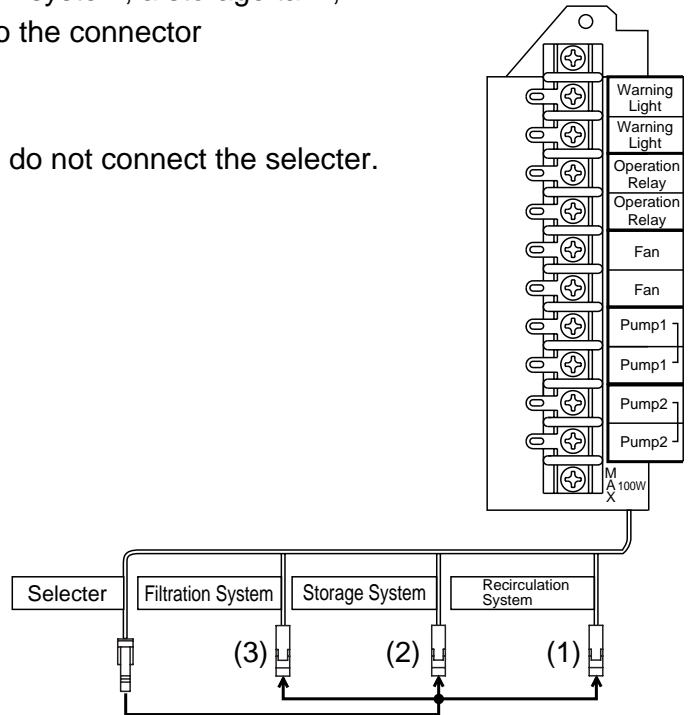

System Controller Terminals (Optional Connections)

Warning Light

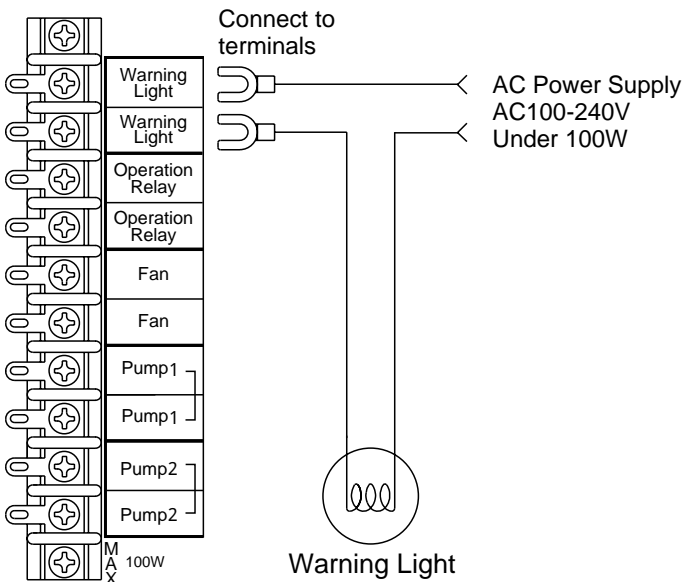

- A warning light can be connected to the system as above to warn of any abnormal operation. When this light flashes, check for an error code on the remote controller and diagnose accordingly.

Operation Light

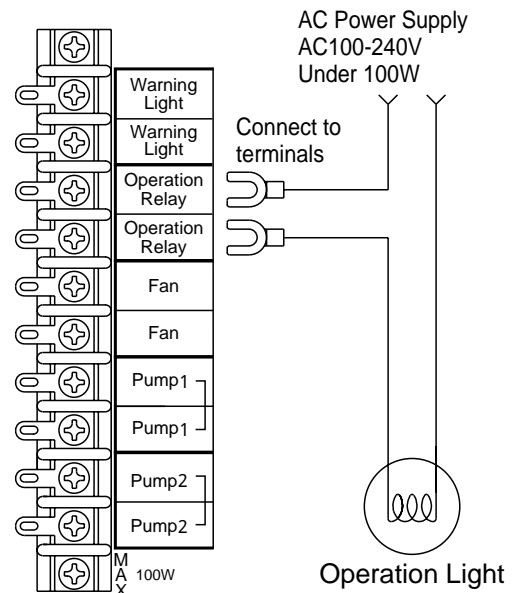

- An operation light can be connected to the system controller as above in order to indicate when power has been turned on to the system.

Circulation Pump Terminals

- Use these terminals to control the pump in any circulating system.
Connected this way, the system controller will control the function of the pump.
- Use a normally open relay to supply power to the pump. Use a thermal relay if necessary.

(1) When operating with 1 circulation pump

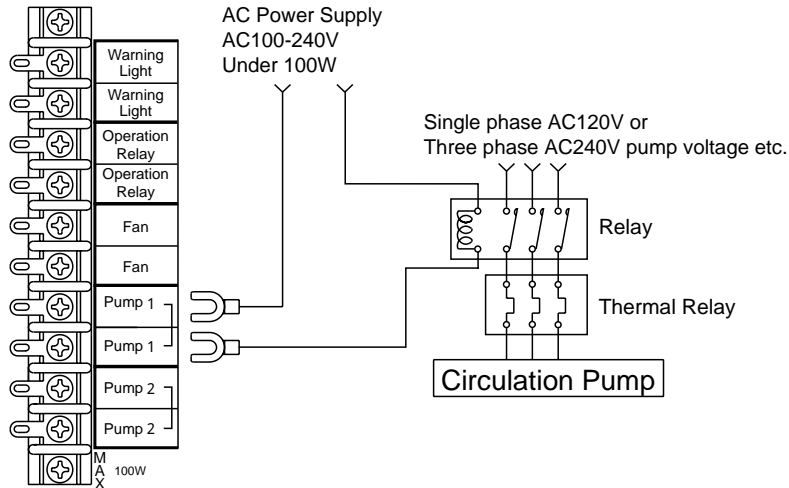

* If there is only one pump, connect to "Pump 1" terminals.

(2) If two circulating pumps will be used:

Connect as below if two circulating pumps will be used. The two pumps can be set to alternate with a dipswitch change.

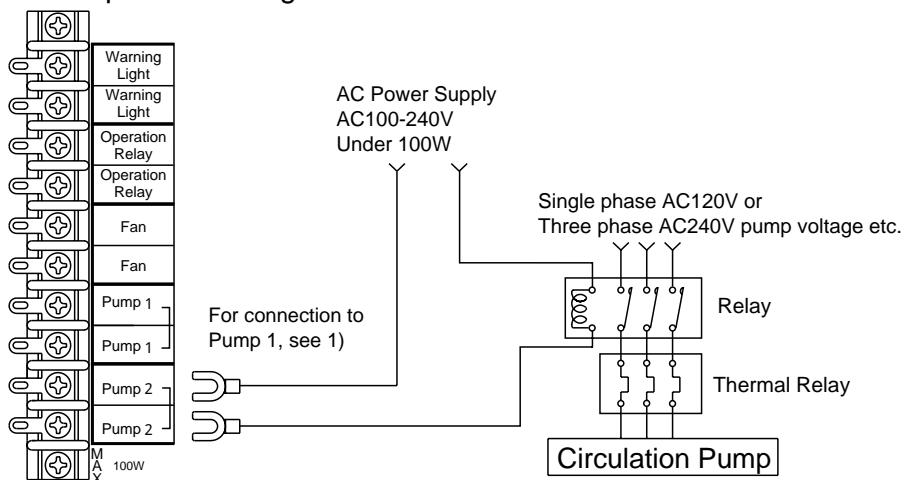

- * Do not connect both Pump 1 and Pump 2 to the same terminal block.
- * After connecting as shown above, set dipswitch 3 to "OFF". (See page 14 or 15)

• Piping diagram for parallel pipe installation

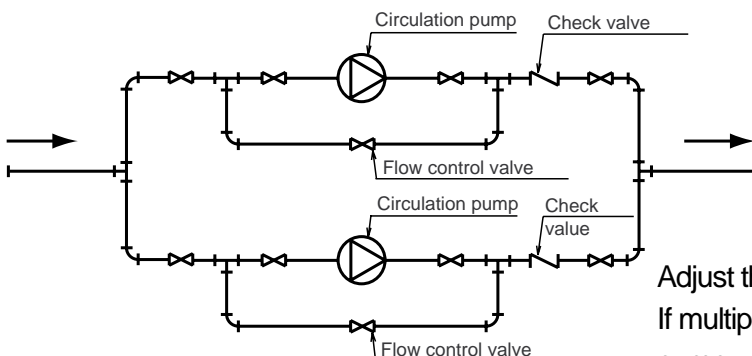

Adjust the pump flow with the flow control valves.
If multiple pumps are used, control the flow of each pump with separate valves.

Exhaust Fan Terminal

- These terminals will close when any of the units are heating or when the fan on any of the units is blowing. These terminals can be used to control an exhaust fan or damper in this way.
- Use a relay to provide power to the fan or damper. Use an additional thermal relay if necessary.

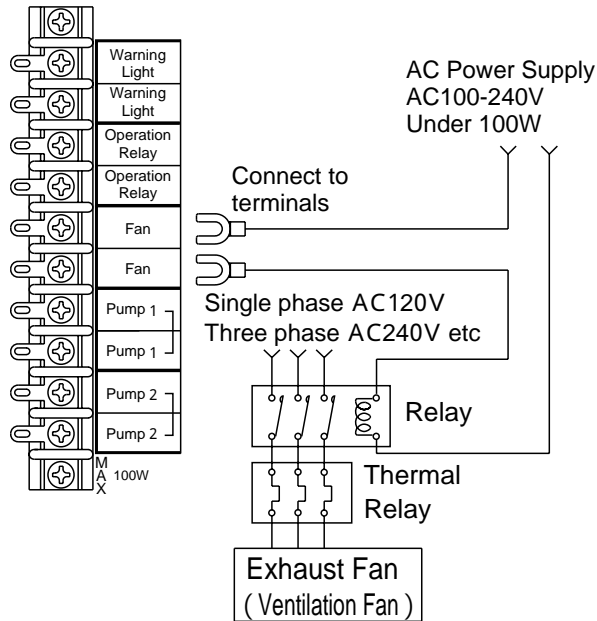

Pressure Switch/Safety Shutoff Switch and External Operation Switch Connections

Pressure Switch/Safety Shutoff Switch Connection

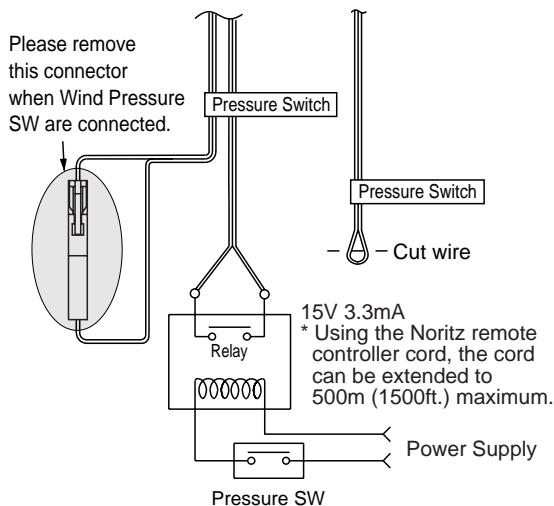

- A pressure switch or other safety device can be installed to shut down the system under unsafe or improper operation.
- Please use a low voltage (15V) junction, normally open relay.
- This terminal is short circuited at time of shipment.
In order to use this feature, cut the wire labeled "Pressure Switch", connect it to the relay, and disconnect the connector

Connecting the external operation switch

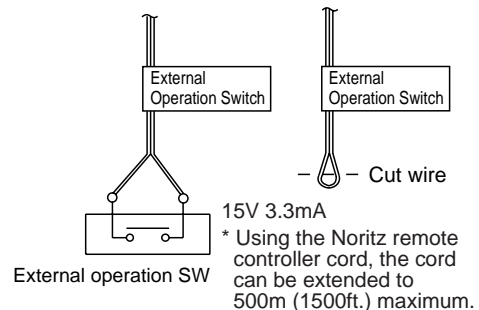

- Follow this procedure to use an external switch to turn power on and off to the unit instead of the remote controller.
 - (1) The power to the units will be on when the external switch is turned on (closed).
 - (2) The power to the units will be off when the external switch is turned off (open).
- Use a low voltage (15V) junction.
 - * If the units are installed with a recirculation system, a storage tank or a filtration system, the pump will also turn on or off with this switch.

Multi-System

A. Installation without a recirculation system

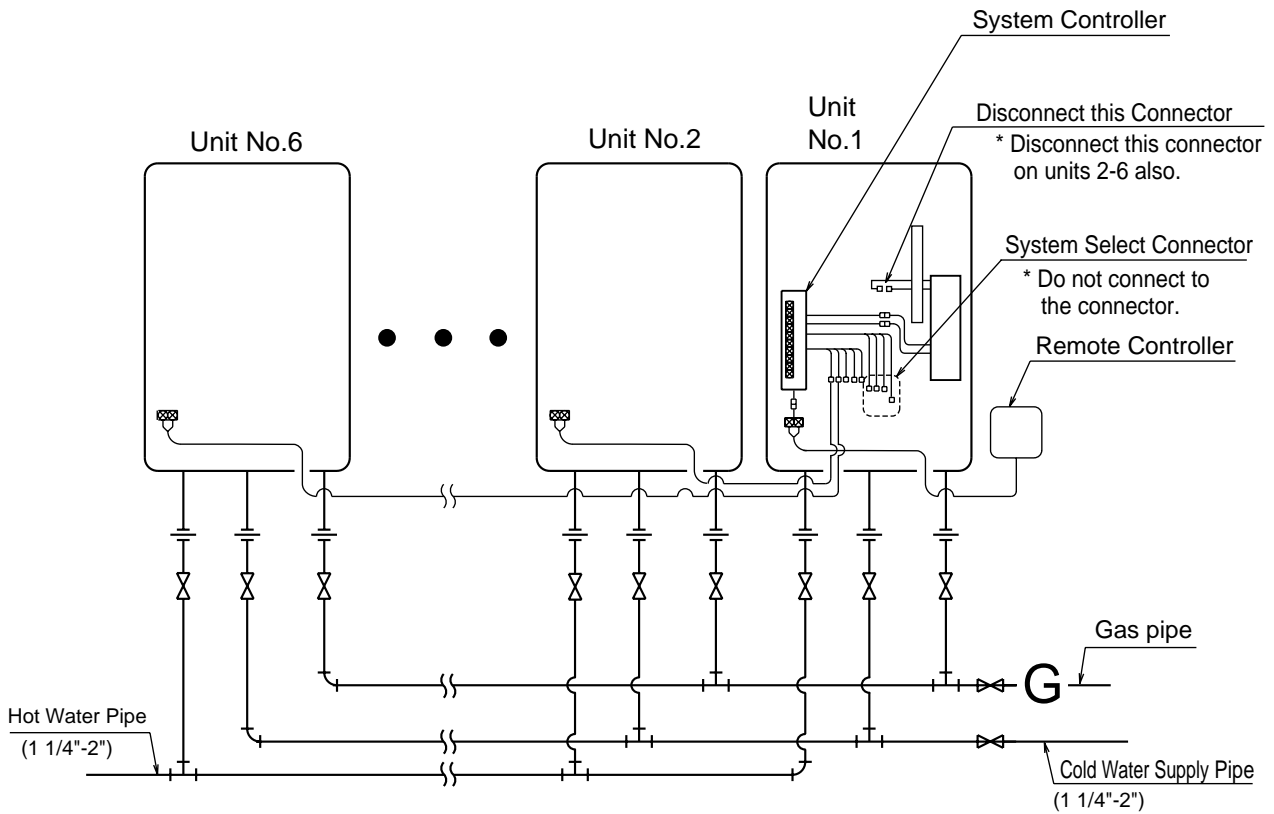

- Insulate or apply heating materials to both the cold water supply piping and the hot water piping to prevent freezing during cold weather and to prevent heat loss through the piping.

B-1. Example of Recirculation with a Multi-System

This system will make hot water more quickly available to remote fixtures. The pump will circulate water through the loop until the entire loop is warm, and then the system controller will turn off the pump until the loop cools down.

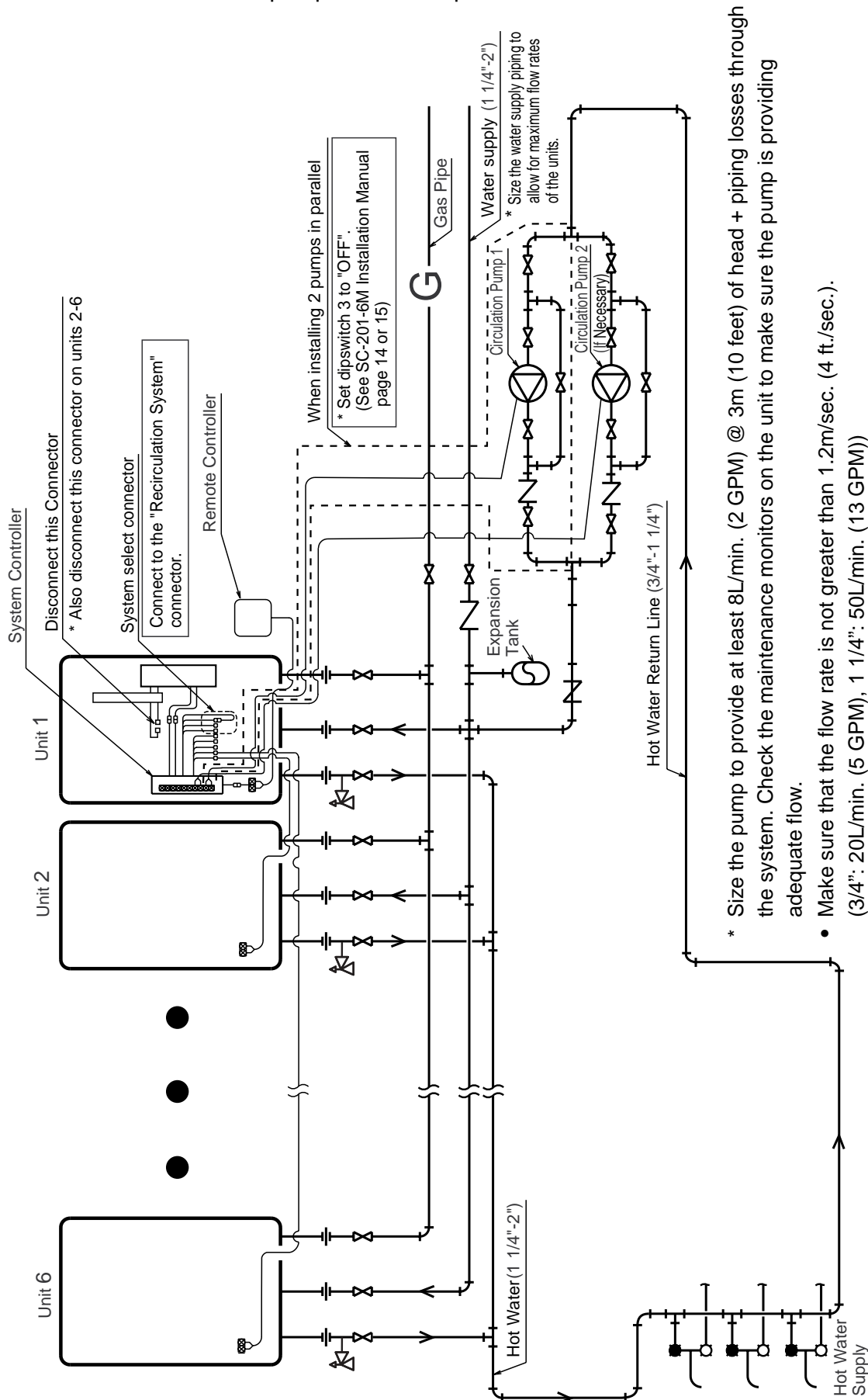

- * Size the pump to provide at least 8L/min. (2 GPM) @ 3m (10 feet) of head + piping losses through the system. Check the maintenance monitors on the unit to make sure the pump is providing adequate flow.
- Make sure that the flow rate is not greater than 1.2m/sec. (4 ft./sec.). (3/4": 20L/min. (5 GPM), 1 1/4": 50L/min. (13 GPM))
If the flow is too low, the recirculation loop temperature will not be warm enough, if the flow is too high, the lifetime of the unit will be reduced.
- * If there are multiple circulation loops, try to make the flow rate 3 - 5L/min. (.75 - 1.25 GPM) in each loop.
- * Use copper or stainless water piping for the entire system.

B-2. Example of Installation with a Storage Tank and Recirculation System

The pump will push water through the Multi-System to heat up the tank.

When the return temperature is high, the flow within the device will be limited to 10L/min. (2.5 GPM)*.

(For the 84M, the flow will be limited to 1.25 GPM.)

(For the KM3211WH and (L)WH(X)56, the flow will be limited to 5L/min.)

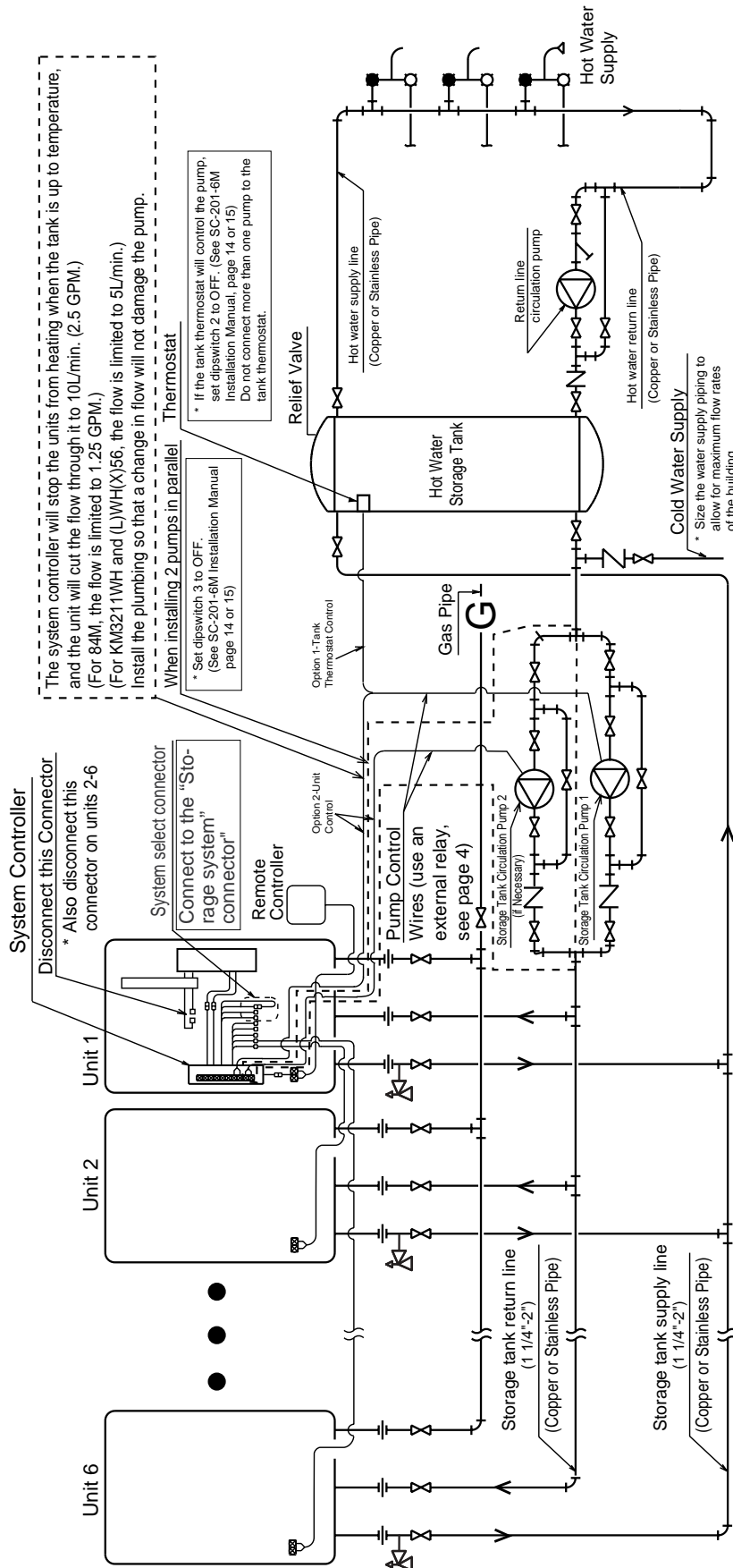

* For the set temperature of the remote control, use the set temperature (of the thermostat) + about 5°C (9°F).

* To achieve the highest recovery, size the storage tank circulation pump for maximum capacity.

[(N-132M: 12 GPM (each) @ 50 ft. of head (160°F setting or less), N-084M: 7.4 GPM (each) @ 40 ft. of head (160°F setting or less) + piping losses through the system.) Verify that the supply pressure to the units is at least 30 PSI.]

[KM3211WH (L)WH(X)56: 32L/min. (each) @ 12 m of head + piping losses through the system.]
 Verify that the supply pressure to the units is at least 0.2MPa (2 bar).

2. Gas Piping

Follow the instructions from the gas supplier.

Gas Connection

- Gas flex lines are not recommended unless they are sized for the maximum input kW (Btu/h·MJ) of each unit.
- Do not use piping with a diameter smaller than the size of the gas inlet to each unit
- After installation, check the gas line for any leaks before using.

Gas Valve

Install a gas shutoff valve for every unit installed.

Gas Meter

Select a gas meter capable of supplying the entire kW (Btu/h·MJ) demand of all gas appliances that the meter serves. Size the gas line for the entire kW (Btu/h·MJ) demand also.

3. Water Piping

Ask a qualified plumber to perform the installation. Observe all applicable codes.

- The plumbing should be installed by a qualified plumbing contractor according to all applicable codes and regulations.
- Insulate or apply heating materials to the supply and hot water piping to prevent freezing during cold weather and to prevent heat loss through the piping.
- Use a union coupling or flexible pipe for connecting the units to ease service and maintenance.
- Refer to the system diagrams for supply and hot water pipe sizing. Do not install piping that is smaller than the inlet or outlet water connections on the units.
- If using an expansion tank, make sure it is correctly sized for the system.
- Use only copper or stainless steel pipe for all plumbing.
- Keep the plumbing as simple as possible.
- Avoid using pipes in which air can accumulate.
- * Use only approved materials, and have the installation inspected upon completion.

4. Electrical Wiring



NOTICE

- Do not connect electrical power to the unit until all electrical wiring has been completed.
- If the remote controller is not connected to the system, the unit will default to a 60°C (140°F) temperature setting.

N-132M

- (1) When installing the system controller, take care not to damage the internal electrical components in the unit and tie off loose electrical cords with the included vinyl ties.
- (2) Remove the connector from the circuit board to the remote controller terminal block in the unit. Connect this disconnected connector labeled 90 from the circuit board to the connector labeled 90 from the system controller.
- (3) Connect the connector from the remote controller terminal block to the connector from the system controller labeled "To remote control terminal block".
- (4) Connect the B5 connector from the system controller to the B5 connector of the unit.
- (5) Use the remote controller cords and the cords included with the system controller to connect the system controller to the other units.

Unit 1 (The unit with the System Controller)

* The remote controller cord can be extended up to 100m (300 ft.).

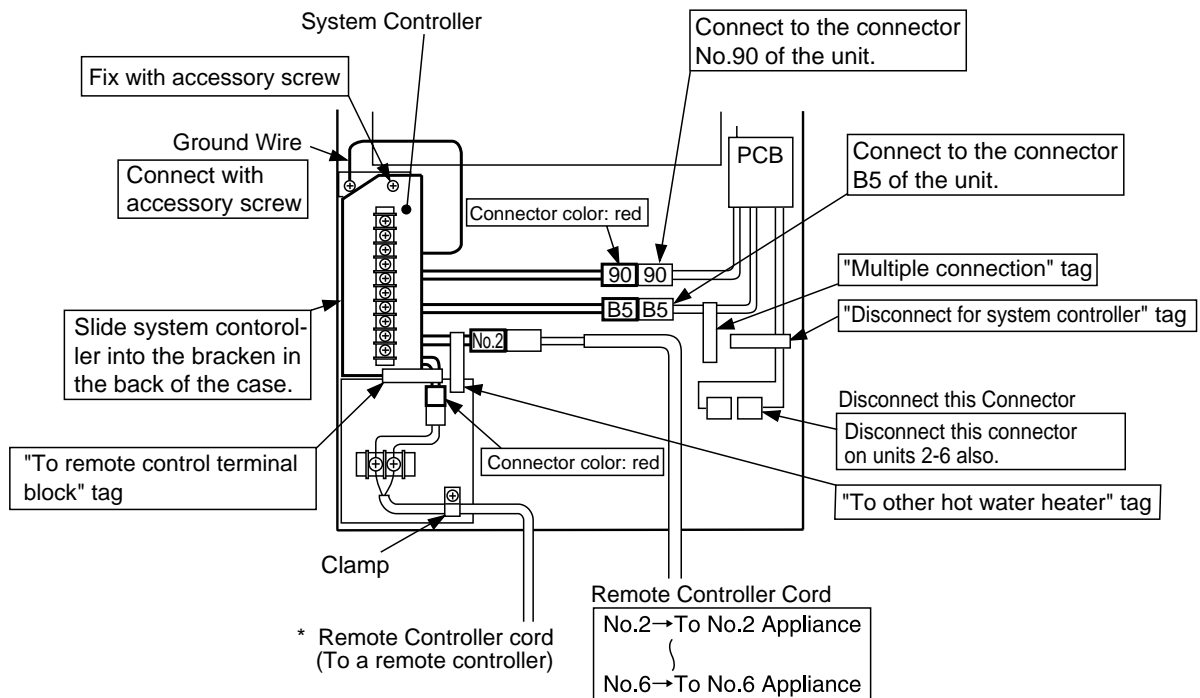

Units 2-6 (Connect each unit to corresponding wires labeled 2-6 from the system controller)

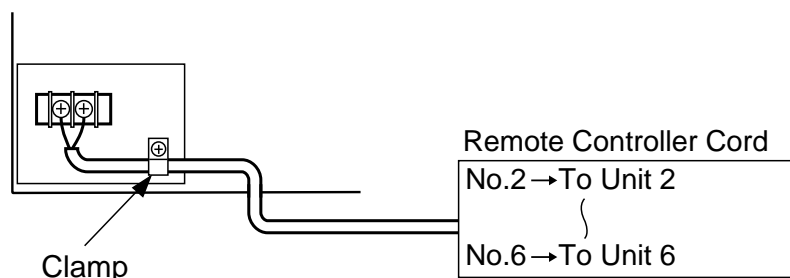

N-084M (-DV), KM3211WH, (L)WH(X)56

- (1) When installing the system controller, take care not to damage the internal electrical components in the unit and tie off loose electrical cords with the included vinyl ties.
- (2) Remove the connector from the circuit board to the remote controller terminal block in the unit. Connect this disconnected connector labeled 90 from the circuit board to the connector labeled 90 from the system controller.
- (3) Connect the connector from the remote controller terminal block to the connector from the system controller labeled "To remote control terminal block".
- (4) Connect the B5 connector from the system controller to the B5 connector of the unit.
- (5) Use the remote controller cords and the cords included with the system controller to connect the other units to the system controller.

Unit 1 (The Unit with the System Controller)

* The remote controller cord length

When using one remote controller = Maximal length 100m (300ft.).

When using two remote controllers = within 50m (150ft.) each (KM3211WH, (L)WH(X)56 only).

When using three remote controllers = within 20m (65ft.) each (KM3211WH, (L)WH(X)56 only).

* Please refer to the installation manual of the unit about version, quantity of the remote controller which can connect.

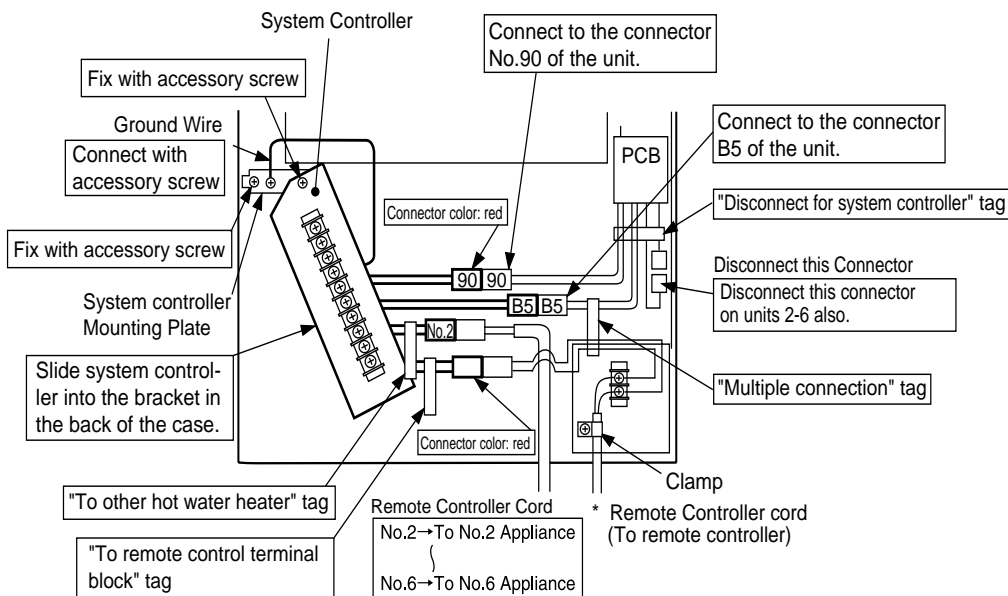

Units 2-6 (Connect each unit to corresponding wires labeled 2-6 from the system controller)

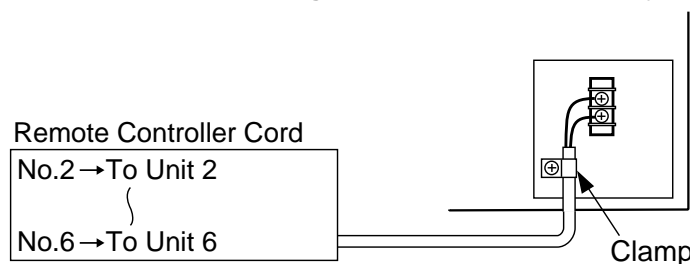

When installing 2 or more multi-systems

Install one remote controller for every system controller. When wiring, make sure the remote control cords are no longer than 100m (300 ft.).

5. Trial Operation

The installer should test operate the system, explain to the customer how to use the units, and give the owner the Installation and Operation Manual before leaving the installation.

- (1) Connect electrical power to each of the units.
 - (2) Open the gas shutoff valve, the main water valve, and the water shutoff valves on all of the units.
 - (3) Turn the power ON with the remote controller. (The Operation Lamp will light up.)
 - (4) Slowly open a hot water fixture and confirm that the units ignite in sequence and that the Burner On Lamp on the remote controller lights.
- If an "11" or "12" error code flashes on the remote controller, there may be air in the gas line. Hit the Power Button ON and OFF a few times and then open the fixture again to try igniting the unit again.
 - If this fixture does not cause all of the units to ignite, test the rest of the units by switching which is the primary unit by pressing either the Maximum or Minimum Manifold Pressure Set Button on the circuit board of the unit.
 - Operate all of the units and confirm that the water temperature corresponds to the temperature set on the remote controller. Set the remote to the lowest temperature to maximize water flow. If the water temperature is hotter than the set temperature, check to make sure that the remote is connected to the system controller, and that the system controller is connected to the other units.
 - If the units do not operate properly, refer to the Troubleshooting section of the Owner's Manual.
- * After the test operation, clean any debris off of the filter on the water inlet.

Checking Water Flow (Maintenance Monitors)

Necessary only for recirculation systems

N-084M(-DV), N-132M

- (1) Press the temperature up and down buttons ○ and ○ simultaneously for more than 2 seconds.
(The remote control will display the maintenance monitors.)
* "Unit No.", "Data No." and "Data" are displayed on the remote controller temperature display.
- (2) Press the "FLOW METER ALARM SET" button to change which unit's information is being displayed.
(The combustion lamp of the selected unit will flash twice.)
* When switching "Unit No.", the display will change from "5C 01 Data No." "01 02 Data No." "02 03 Data No." . . . "(Last Unit)No. 5C OFF" when the "FLOW METER ALARM SET" button is pressed.
If the "FLOW METER ALARM SET" button is not pushed to change the Unit No., the Data No. for that Unit will then be displayed on the remote controller.
- (3) Press the temperature up or down buttons ○ or ○ to select Data No.14. The water flow through that heater will be displayed.
- (4) Repeat (2) - (3) for all water heaters. Adjust so that the total water flow of all devices is 2 GPM or more.
- (5) Press the temperature up and down buttons ○ and ○ simultaneously for over 2 sec. to return to the temperature display.

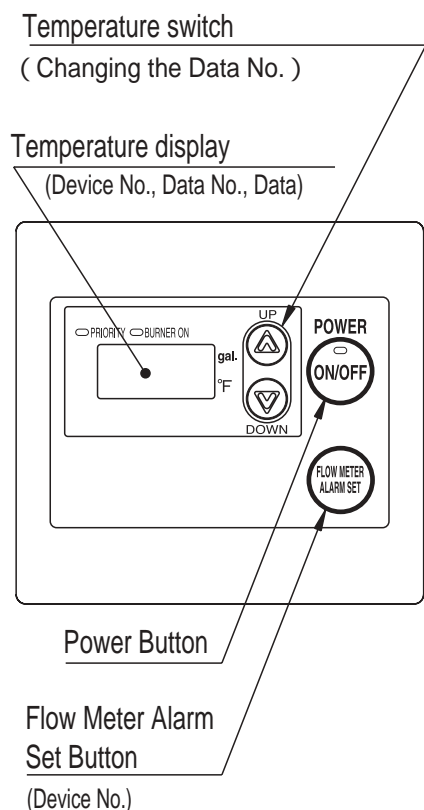

KM3211WH, (L)WH(X)56

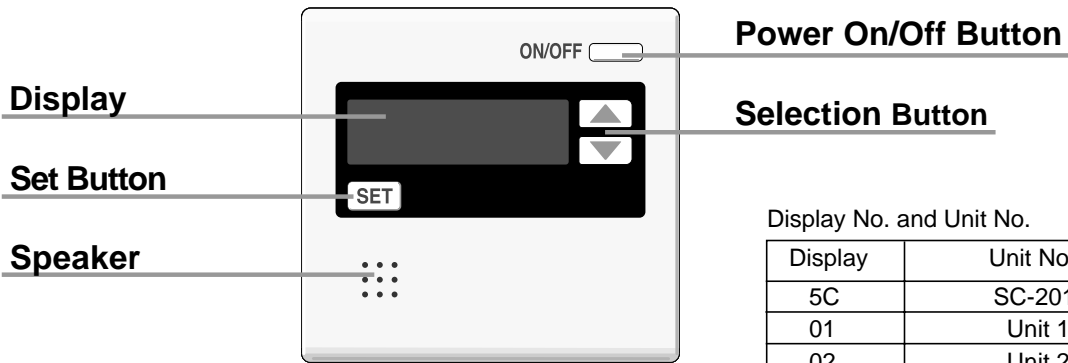

Display No. and Unit No.

Display	Unit No.
5C	SC-201
01	Unit 1
02	Unit 2
⋮	⋮
06	Unit 6

The Power On/Off Button can be set to either "ON" or "OFF" unit operation will not be affected by this setting. However, be sure to set the Power On/Off Button to "ON" after turning on the power.

<Display procedure>

- (1) Press and hold both the up [▲] and down [▼] select buttons simultaneously for more than five seconds.
 - (2) "Maintenance Monitor" display will appear along with the data no. and data.
 - (3) Displaying data and switching data no.
 - a) Press the up [▲] select button to switch display to the next item no. Press the down [▼] set button to switch display to the previous data no.
 - b) Press the set button to switch to the mode for changing the ten's digit. Use the select buttons [▲] and [▼] in the same manner as 1) to make changes.
 - c) When pressing the setting button again:
 - If the data no. is 03, the microcomputer name of the remote controller is displayed. When the set button is pressed again, the unit will return to the mode of 1).
 - If the data no. is other than 03, the unit will return to the mode of 1).
 During maintenance monitors are displaying, the hot water temperature and other settings cannot be adjusted.
 - (4) Press the temperature up or down buttons [▲] or [▼] to select Data No.14. The water flow through that heater will be displayed.
 - (5) Repeat (3) - (4) for all water heaters. Adjust (so that) the total water flow of all devices is 8L/min. or more.
- <Returning to Normal Mode>
- (1) For releasing the indication, press and hold both up [▲] and down [▼] of select buttons simultaneously more than two seconds, or leave it alone for more than 10 minutes.

Dipswitch Settings

N-084M(-DV), N-132M

Disconnect the power to the units before changing the dipswitches.
(Otherwise, settings will not take effect.)

: ON : OFF

Dipswitch	SW1	SW2	SW3	SW4	SW5	SW6	SW7	SW8
		Pump abnormality detection	Pump rotation	125° F recovery during high-temperature setting				
		Yes	No	Set temperature				
		No	Yes	125° F				

* All dipswitches are set to ON from the factory.

SW2: Pump abnormality detection

Set to OFF if the pump will not be connected to the system controller, but instead the pump will be controlled by an external control device.

SW3: Pump rotation

Set to OFF if using 2 pumps.

SW4: If the switch is set to OFF, and the Power Button is turned OFF and ON, the unit will accept 125°F return water (if the unit is set at that temperature or higher).

When the dipswitch is ON, the unit will allow the standard return temperature.

* Do not change any other dipswitches.

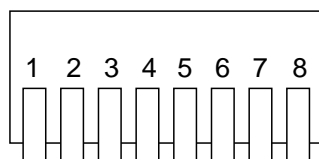
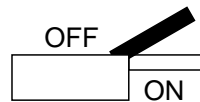

Dipswitch Settings

KM3211WH, (L)WH(X)56

Disconnect the power to the units before changing the dipswitches.
(Otherwise, settings will not take effect.)

: ON : OFF

Dipswitch	SW1	SW2	SW3	SW4	SW5	SW6	SW7	SW8
		Pump abnormality detection	Pump rotation	60°C recovery during high-temperature setting	Power Button works with circulation			
		Yes	No	60°C	Interlock			
		No	Yes	Set temperature	Independence			

* All dipswitches are set to ON from the factory.

SW2: Pump abnormality detection

Set to OFF if the pump will not be connected to the system controller, but instead the pump will be controlled by an external control device.

SW3: Pump rotation

Set to OFF if using 2 pumps.

SW4: The setting temperature which the Power Button is turned ON, and OFF when the setting is high temperature.

When the setting temperature is changed above 60°C, turn the Power Button OFF once, then 60°C is displayed when turning the Power Button ON again.

(When the dipswitch is ON.)

When the dipswitch is switched to OFF, the temperature will remain at the previous setting. (before the Power Button is turned to ON.)

SW5: Behavior when turning on the Power Button with remote controller or external operation terminal. When the dipswitch is set to ON, the Power Button and the circulation switch are turned ON at the same time.

When the dipswitch is turned to OFF, only the Power Button is turned to ON.

* Do not change any other dipswitches.

